

JAVES

Projection Products

JAVES SLC-515SA



Digital LCoS Projector User Manual



Warning Statement

All contents subject to change without notice

WARNING

This equipment has been tested and found to comply with the limits for a Class A digital device, pursuant to Part 15 of the FCC Rules. These limits are designed to provide reasonable protection against harmful interference when the equipment is operated in a commercial environment. This equipment generates, uses, and can radiate radio frequency energy and, if not installed and used in accordance with the instruction manual, may cause harmful interference to radio communications. Operation of this equipment in a residential area is likely to cause harmful interference in which case the user will be required to correct the interference at his own expense.

You are cautioned that any changes or modifications not expressly approved in this manual could void your authority to operate this equipment. The shielded interface cable recommended in this manual must be used with this equipment in order to comply with the limits for a digital device pursuant to Subpart B of Part 15 of FCC Rules.

WARNING

This is a Class A product. In a domestic environment, this product may cause radio interference in which case the user may be required to take adequate measures.

WARNING

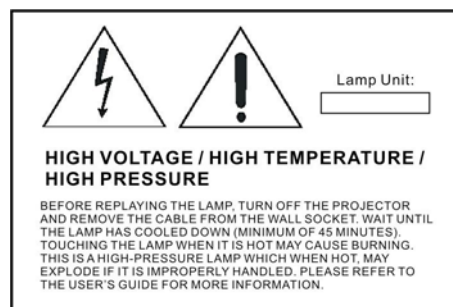

Table of contents

Important safety instructions

Introduction

Projector features

Shipping contents

Projector exterior view

Front / upper side

Left side view

Right side view

Lower side

Controls and functions

External control panel

Remote control

Remote control effective range

Replacing the remote control battery

Positioning your projector

Choosing a location

Connection

Cable connection

Connecting a computer

Connecting Video source devices

Operation

Start up

Switching input signal

Shutdown

Menu operation

Menu system

Picture menus

Safety instructions for ceiling mounting of your Thomson projector

Troubleshooting

Maintenance

Care of the projector

Cleaning the lens

Cleaning the projector case

Storing the projector

Transporting the projector

Specifications

Projector specifications

Dimensions

Important safety instructions

- Operate the unit on 200 – 240 V AC, 50/60 Hz or 100 – 240 V AC, 50/60 Hz to DC 15V 7A power adaptor
- Should any liquid or solid object fall into the cabinet, unplug the unit and have it checked by qualified personnel before operating it further.
- Unplug the unit from the wall outlet or set the power switch to OFF position if it is not to be used for several days.
- To disconnect the cord, pull it out by the plug. Never pull the cord itself.
- The wall outlet should be near the unit and easily accessible.
- The unit is not disconnected from the AC power source (mains) as long as it is connected to the wall outlet and the power switch is set to the OFF position.
- Do not look into the lens while the lamp is on.
- Do not place your hand or objects near the ventilation holes. The air coming out is hot.
- Avoid using an extension cord with a low voltage limit, as it may cause short-circuiting and physical injury.
- Do not catch your finger between the unit and surface of the floor when moving the projector installed on the floor.
- Be careful not to catch your finger in the cooling fan.

Introduction

Projector features

The projector integrates high-performance optical engine projection and a user-friendly design to deliver high reliability and ease of use.

The projector offers the following features:

- Quick cooling function for reducing projector cooling time
- Compact and portable unit
- High quality short throw lens
- Adjustable color balance control for data/video display
- 50W HID projection lamp with 4500K color
- Ability to display 16.7 million colors
- Multi-language on-screen menus
- Built-in speaker provides mixed mono audio when an audio input is connected
- Powerful AV function to provide high quality AV picture
- Component Progressive compatibility (YPbPr)
- External Power Adapter with Universal AC Voltage input 100 – 240V, 15VDC at 7A output.
- **The apparent brightness of the projected image will vary depending on the ambient lighting conditions, selected input source contrast/brightness settings, and is directly proportional to projection distance.**
- **The lamp brightness will decline over time and may vary within the lamp manufacturers specifications. This is normal and expected behavior.**

DVD Combo features

- **96 kHz/24 bit audio D/A converter**
- **12 bit video D/A converter**
- **Multi TV system supported**
- **Graphical user interface screen**
- **Multi-audio function**
- **Multi-subtitles function**
- **Multi-angle function**
- **Parental lock function**
- **Disc formats supported by player**



Shipping contents

The projector is shipped with the cables required for connection to a PC and video output devices. Carefully unpack and verify that you have all of the items shown below. If any of these items are missing, please contact your place of purchase.

The supplied accessories will be suitable for your region, and may differ from those illustrated.

Projector

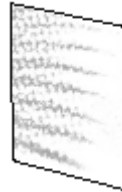

User's manual



VGA cable



Video cable



Audio cable



Power cord

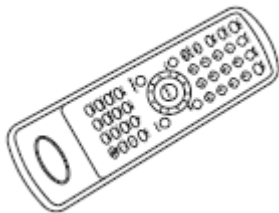

Remote control with battery

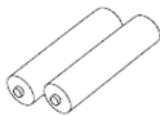

Projector exterior view

Front / upper side

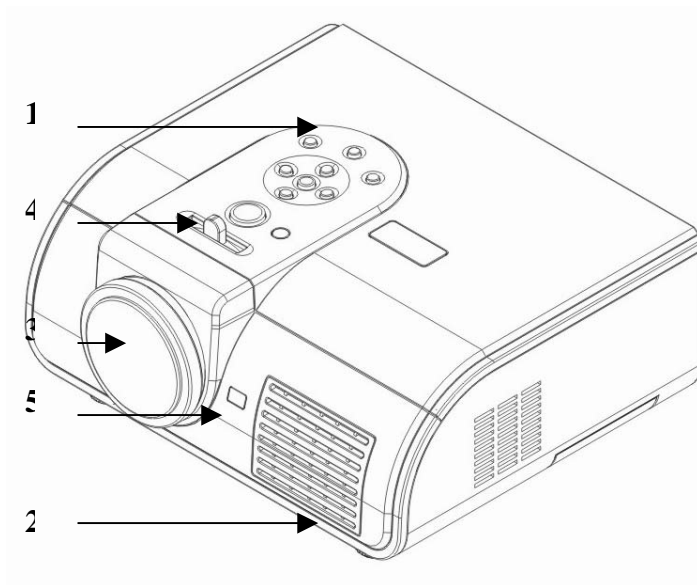

- 1. External control panel
(See ["External control panel"](#) on page 9 for detailed information.)
- 2. Ventilation grill
- 3. Lens cap
- 4. Focus adjuster
- 5. Front IR remote sensor

Left side view

Refer to ["Connection"](#) on page 18 for more information on making connections to various equipment.

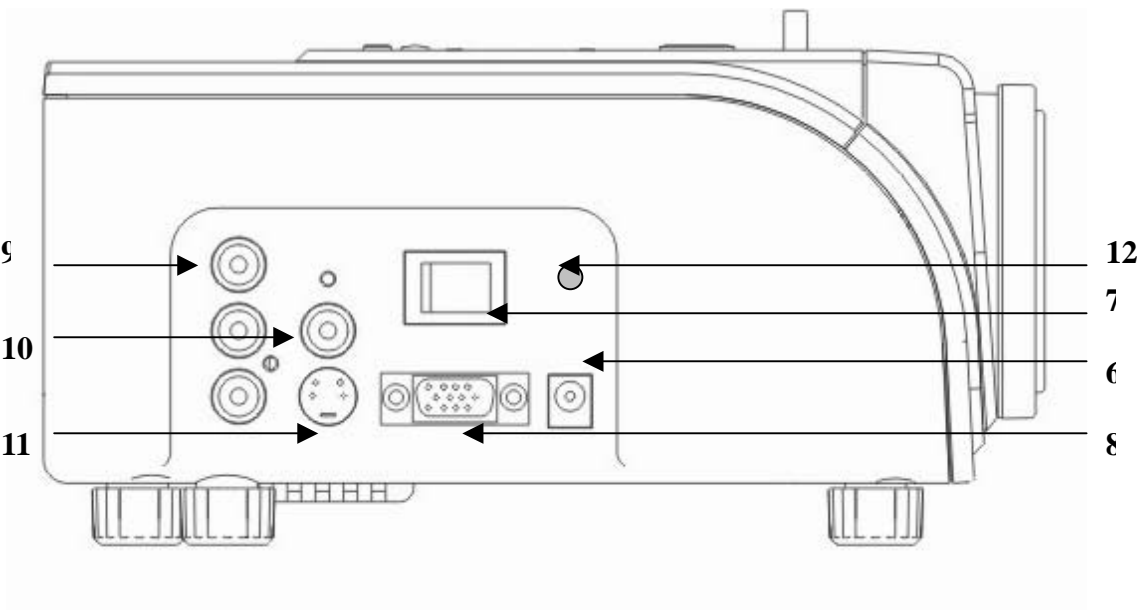

- 6. 15VDC Power jet input
- 7. Main Power Switch
- 8. RGB (PC)
- 9. Component video (YPbPr/YCbCr) input socket
- 10. Video input socket
- 11. S-Video input socket
- 12. 3.5mm Audio in Phonejet

Right side view

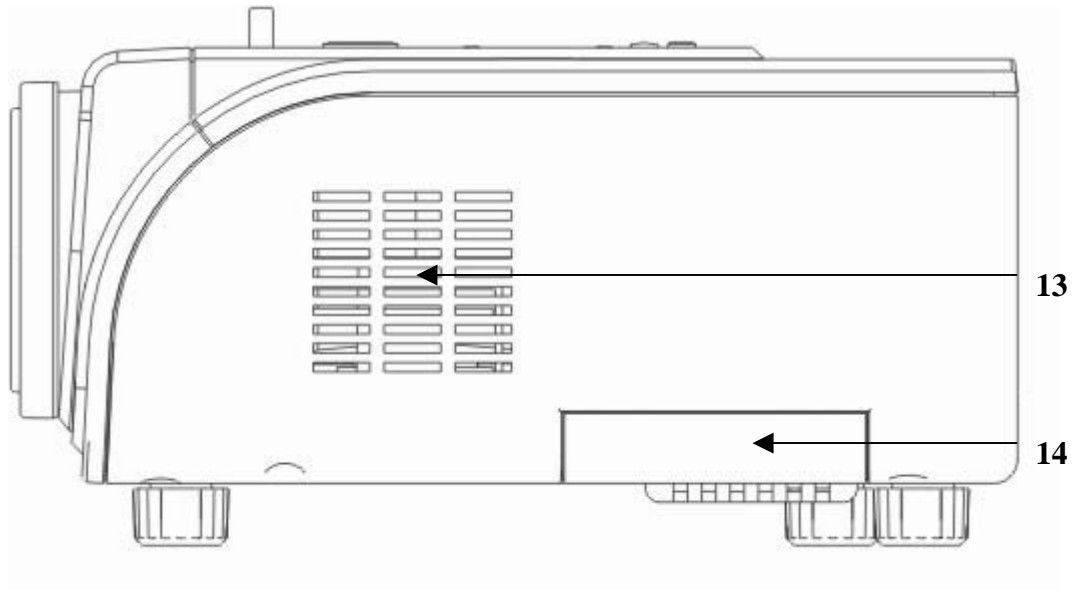

13. 5W mono speaker

14. Lamp cover

Lower side

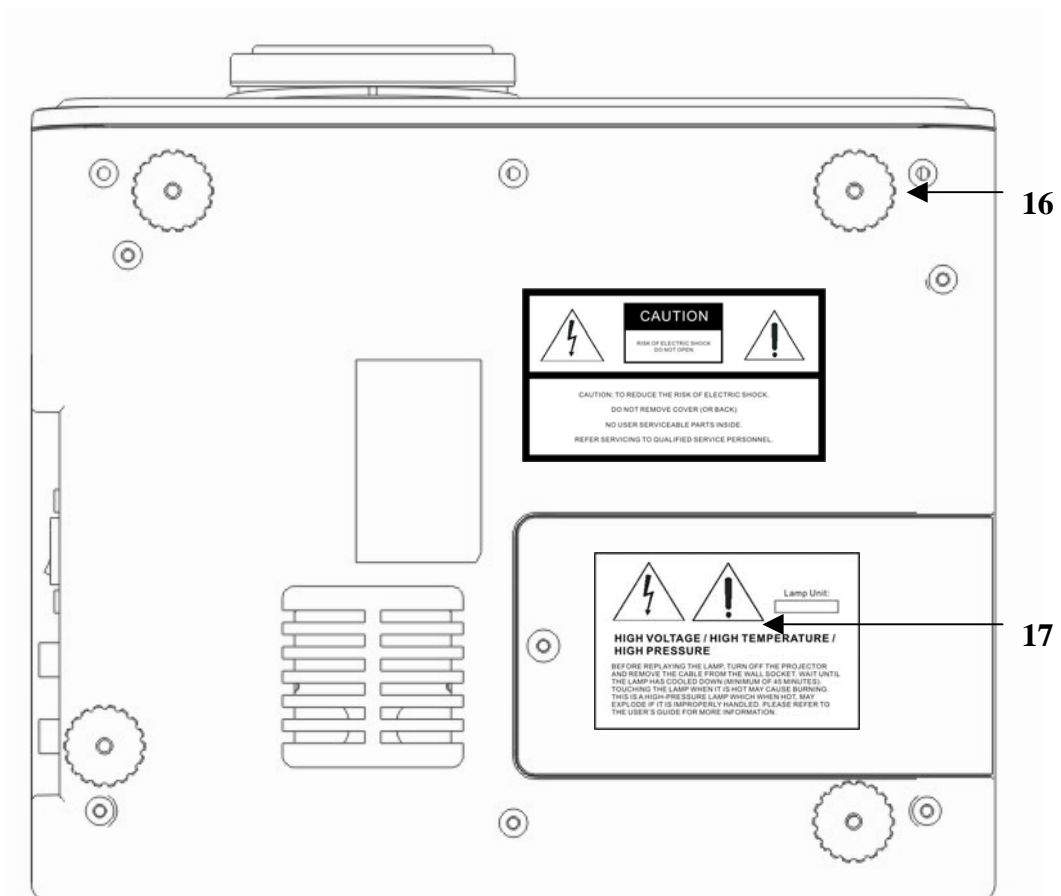

15. Lamp Cover

16. Ceiling mount and adjustable feet

Controls and functions

External control panel

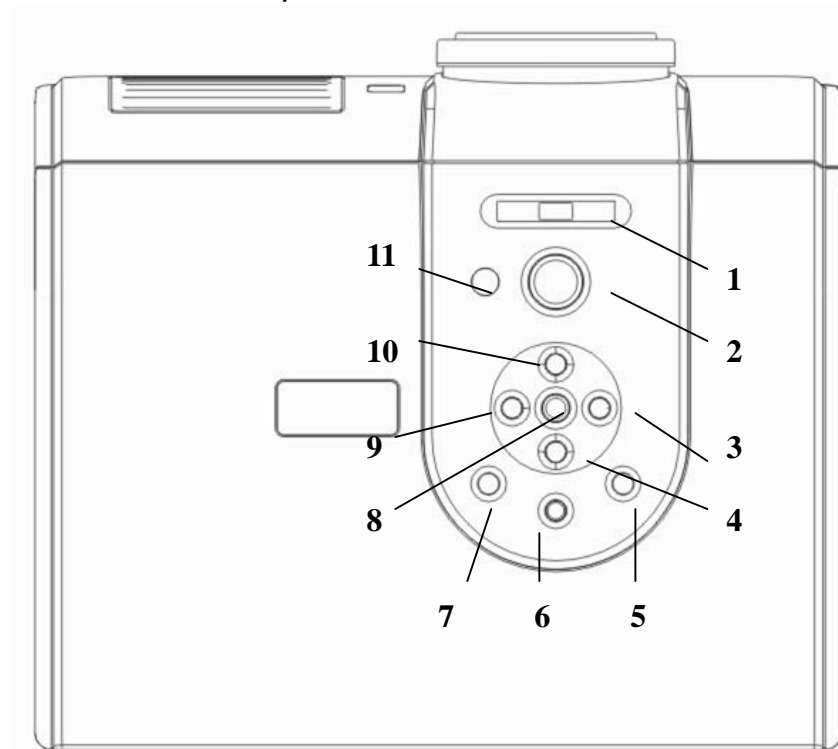

1. Focus adjuster, lens focus can be adjusted by this key.
2. Power (Refer to ["Start up" on page 25](#) and ["Shutdown" on page 30](#) for more information.)
Turns the projector on or off.
3. Right key. (OSD control only)
4. Down key. (OSD control only)
5. Volume increase. Digital volume control
6. OSD Menu. Menu recalls for OSD.
7. Volume decrease. Digital volume control.
8. OSD Enter/Source (Refer to ["Switching input signal" on page 29](#) for more information.)
Sequentially selects the input signal Video. , S-Video, Component Video, or RGB.
9. Left Key. (OSD control only)
10. Up key. (OSD control only)
11. Top Infra-red sensor.

Remote control

POWER - Turns the projector on or off.

DVD Section:

SUBTITLE – Display the different subtitle languages on the screen.

AUDIO – Select the sound track.

SEARCH – Search the desired point by enter NUMERIC button to choose number corresponding.

REPEAT – Repeat play one chapter or one title (for DVD), or repeat play the current track or the whole tracks (for VCD/CD).

MENU – Select Playback Control for VCD if PBC is on, or return to DVD main menu.

TITLE – Return the DVD title or return root.

SETUP – DVD player advance system setting

SLOW – Reduced the playing speed to 1/2, 1/4, 1/8, 1/16 of normal speed.

DISPLAY – Display the elapsed time and remaining time.

ANGLE – Display the angle number and change to the different angles.

Projector Section:

SOURCE - Sequentially selects the input signal Video, S-Video, Component Video, or RGB.

MUTE – Audio mute on or off

Display – Display the video standard and mode

UP – Up key for OSD control

LEFT – Left key for OSD control

RIGHT – Right key for OSD control

DOWN – Down key for OSD control

ENTER – Enter key for OSD control

VOL+ – Volume increase. Digital volume control.

VOL- – Volume decrease. Digital volume control.

MODE – Sequentially selects video mode Dynamic, Static, Theater, or Game

MENU – OSD menu recall

ALIGNMENT – Display alignment signal for focus adjustment.

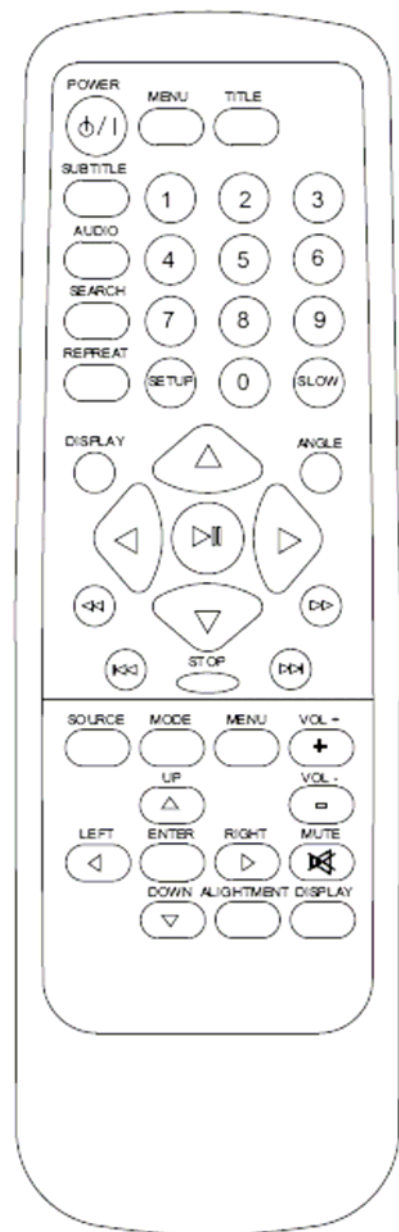

Remote control effective range

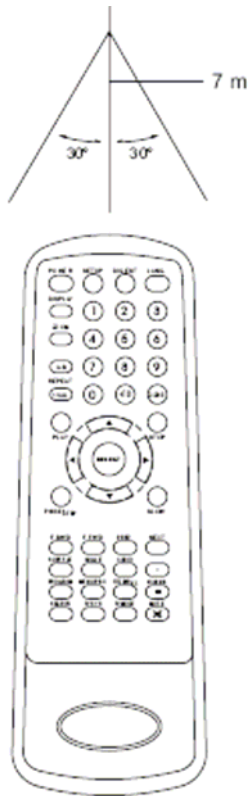

Infra-Red (IR) remote control sensors are located on the front and the back of the projector.

The remote control must be held at an angle within 30 degrees of the projector's IR remote control sensors to function correctly. The distance between the remote control and the sensors should not exceed 6 meters (~ 20 feet).

Make sure that there are no obstacles between the remote control and the IR sensors on the projector that might obstruct the infra-red beam.

Replacing the remote control battery

Insert the batteries while observing the correct (+) and (-) polarities as illustrated at below.

Service life of batteries

- The batteries normally last for about one year although this depends on how often, and for what operations, the remote control unit is used.
- If the remote control unit fails to work even when it is operated near the player, replace the batteries.
- Use 2 size AAA batteries.

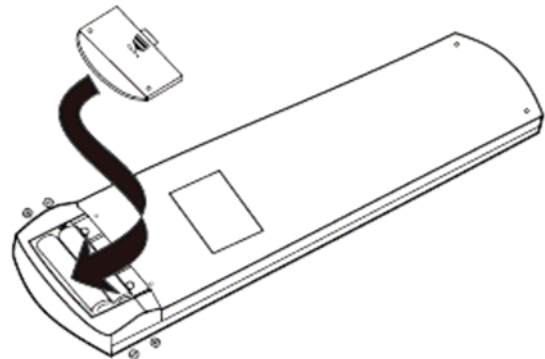

• Positioning your projector

Choosing a location

Your projector is designed to be installed in one of four possible installation locations:

1. Floor in front of screen;
2. Ceiling in front of screen;
3. Floor at rear of screen;
4. Ceiling at rear of screen.

Your room layout or personal preference will dictate which installation location you select.

Take into consideration the size and position of your screen, the location of a suitable power outlet, as well as the location and distance between the projector and the rest of your equipment.

If you use the projector with wireless function, there's no need to worry about data cable connections. This gives you the flexibility to site the projector anywhere in the room up to a range of 20m away from your notebook, and switch between presentations on different notebooks instantly without fiddling with cables

I. Floor front

Select this location with the projector placed near the floor in front of the screen. This is the most common way to position the projector for quick setup and portability.

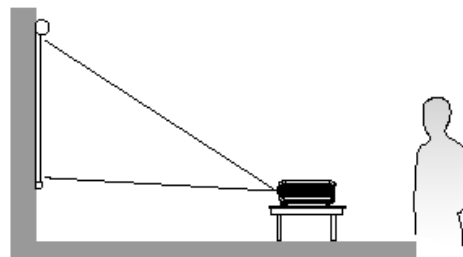

II. Ceiling front

Select this location with the projector suspended upside-down from the ceiling in front of the screen. Purchase the Thomson Projector Ceiling Mounting Kit from your dealer to mount your projector on the ceiling.

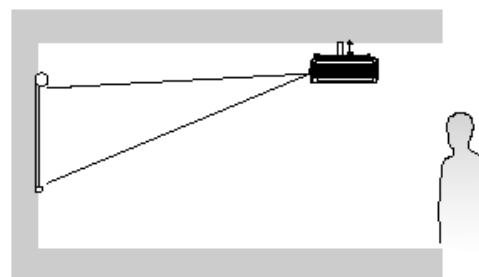

III. Floor rear

Select this location with the projector placed near the floor behind the screen.

Note that a special rear projection screen is required.

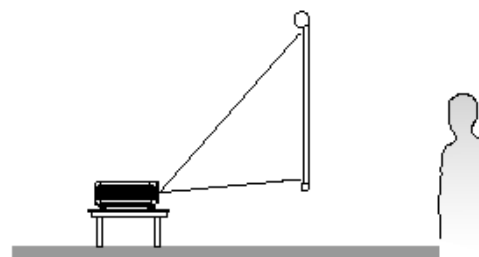

IV. Ceiling rear

Select this location with the projector suspended upside-down from the ceiling behind the screen.

Note that a special rear projection screen and the Thomson Projector Ceiling Mounting Kit are required for this installation location.

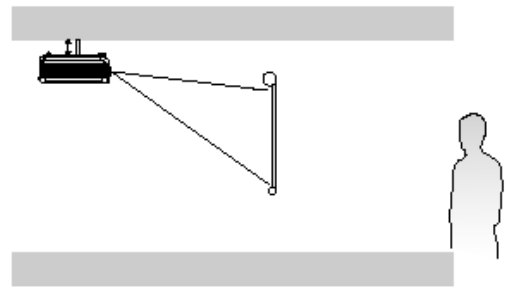

Connection

When connecting a signal source to the projector, be sure to:

1. Turn all equipment off before making any connections.
2. Use the correct signal cables for each source.
3. Ensure the cables are firmly inserted.

In the connections shown below, some cables may not be included with the projector (see "[Shipping contents](#)" on page 6). They are commercially available from electronics stores.

Cable connection

Connecting a computer

Connecting a computer

The projector provides a VGA socket that allow you to connect it to a notebook or desktop computer.

To connect the projector to a notebook or desktop computer (either through a VGA cable):

1. Take the supplied VGA cable and connect one end to the D-Sub output socket of the computer.
2. Connect the other end of the VGA cable to the D-SUB/COMP IN signal input socket on the projector.
3. If you wish to make use of the projector (mixed mono) speaker in your presentations, take a suitable audio cable and connect one end of the cable to the audio output socket of the computer, and the other end to the AUDIO IN socket of the projector.

• **A Mac adapter (an optional accessory) is needed if you are connecting legacy version Macintosh computers.**

• **Many notebooks do not turn on their external video ports when connected to a projector. Usually a key combo like FN + F3 or CRT/LCD key turns the external display on/off. Locate a function key labeled CRT/LCD or a function key with a monitor symbol on the notebook. Press FN and the labeled function key simultaneously. Refer to your notebook's documentation to find your notebook's key combination.**

Connecting Video source devices

This section describes how to connect the projector to Video source devices using video cables. Video cable connections are recommended for Video presentations.

You can connect your projector to various Video source devices that provide any one of the following output sockets:

- Component Video
- S-Video
- Video (composite)

You need only connect the projector to a Video source device using just one of the above connecting methods, however each provides a different level of video quality. The method you choose will most likely depend upon the availability of matching terminals on both the projector and the Video source device as described below:

Best video quality

The best available video connection method is Component Video (not to be confused with composite Video). Digital TV tuner and DVD players output Component Video natively, so

if available on your devices, this should be your connection method of choice in preference to (composite) Video.

Better video quality

The S-Video method provides a better quality analog video than standard composite Video.

If you have both composite Video and S-Video output terminals on your Video source device, you should elect to use the S-Video option.

Least video quality

Composite Video is an analog video and will result in a perfectly acceptable, but less than optimal result from your projector, being the least video quality of the available methods described here.

Connecting Audio

The projector has a built-in mono speaker which is designed to provide basic audio functionality accompanying data presentations for business purposes only. It is not designed for, nor intended for stereo audio reproduction use as might be expected in home theatre or home cinema applications. Any stereo audio input (if provided), is mixed into a common mono audio output through the projector speaker.

If you have a separate sound system, you will most likely want to connect the audio output of your Video source device to that sound system, instead of to the mono audio projector.

The audio connections illustrated in the following sections are provided for informational purposes only. You need not connect audio to the projector if there is an alternate sound system available, or if audio is not required.

Operation

Start up

1. Plug the power cord into the projector and into a wall socket. Turn on the wall socket switch (where fitted). Check that the Power indicator on our projector adapter lights orange after power has been applied.
2. Plug the DC plug into Projector's 15VDC socket. Remove the lens cap. If it is left on, it could become deformed due to the heat produced by the projection lamp.
3. Switch on the main power at the left side of projector. Check that Power inductor on the projector lights green.
3. Press the Power button on the remote control or projector to start the unit. The Power indicator lights off and lights green after 3 seconds when the unit is on.
4. The start up procedure takes about 5 seconds after pressing Power and mage will appear as normal (If necessary) Rotate the focus ring to adjust the image clearness.

If the projector is still hot from previous activity, it will run the cooling fan for approximately 45 seconds before energising the lamp.

5. Switch all of the connected equipment on.
6. You can also press Source on the projector or remote control to select your desired input signal. For more information, please refer to ["Switching input signal" on page 29](#).

If the frequency/ resolution of the input signal exceeds the projector's operating range, you will see the message "Out Range" displayed on a blue screen.

Switching input signal

The projector can be connected to multiple devices at the same time. However, it can only display one at a time. To cycle through the available input sources, press the Enter button on the projector control panel or the Source button on the remote control. The selected source name will display at the Top-Left of the screen for 10 seconds after each button press.

The brightness level of the projected image will change accordingly when you switch between different input signals. Data (graphic) "PC" presentations using mostly static images are generally brighter than "Video" using mostly moving images (movies).

The input type effects the options available for the Application Mode. See ["Selecting an application mode" on page 29](#) for details.

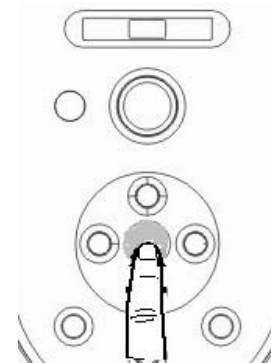

Shutdown

1. Press Power to turn the projector off.
2. The Power indicator light flashes green and the lamp shuts down, the fans continue to run for approximately 45 seconds to cool down the projector.
 - **To protect the lamp, the projector will not respond to any commands during the cooling process.**
 - **To shorten the cooling time, you can also activate the Quick cooling function.**
3. Switch off the main Power at the left side and disconnect the power cord at the adaptor from the wall socket.
 - **Do not unplug the adaptor or power cord before the projector shutdown sequence is complete or during the 45-second cooling down process.**
 - **If the projector is not properly shut down, you risk damaging the lamp. Do not move the projector whilst the lamp is hot.**



Menu operation

Menu system

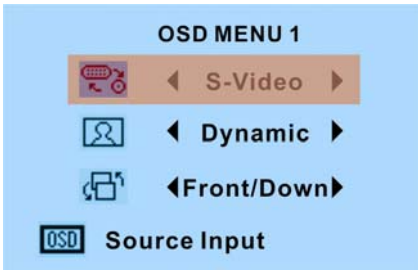
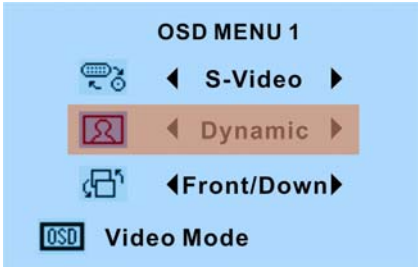
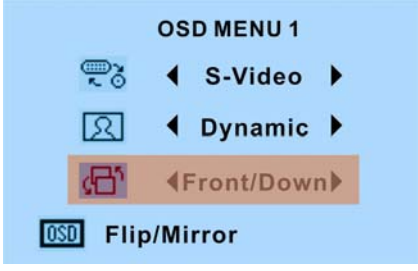
OSD Menu 1

 <p>OSD MENU 1</p> <p>S-Video</p> <p>Dynamic</p> <p>Front/Down</p> <p>OSD Source Input</p>	<p>Video</p> <p>S-Vide</p> <p>YCbCr/YPbPr</p> <p>PC</p> <p>DVD Combo</p>
 <p>OSD MENU 1</p> <p>S-Video</p> <p>Dynamic</p> <p>Front/Down</p> <p>OSD Video Mode</p>	<p>Dynamic</p> <p>Static</p> <p>Theater</p> <p>Game</p>
 <p>OSD MENU 1</p> <p>S-Video</p> <p>Dynamic</p> <p>Front/Down</p> <p>OSD Flip/Mirror</p>	<p>Front/Up</p> <p>Front/Down</p> <p>Rear/Up</p> <p>Rear/Down</p>

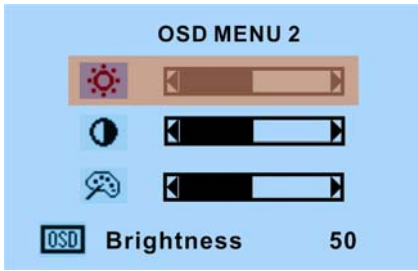
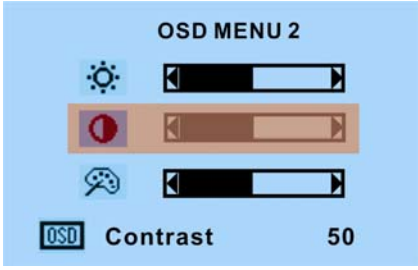
OSD Menu 2

 <p>OSD MENU 2</p> <p>Brightness 50</p>	<p>0 to 100 Brightness (Default 50)</p>
 <p>OSD MENU 2</p> <p>Contrast 50</p>	<p>0 to 100 Contrast (Default 50)</p>
 <p>OSD MENU 2</p> <p>Color 50</p>	<p>0 to 100 Color (Default 50)</p>

OSD Menu 3

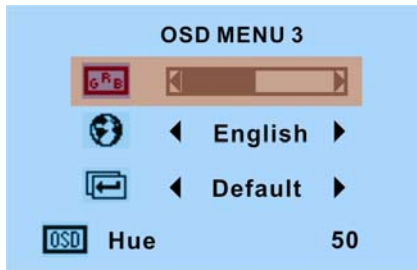

0 to 100 Hue (Default 50)



English
French
German
Spanish
Italian
Dutch
中文繁体
中文简体

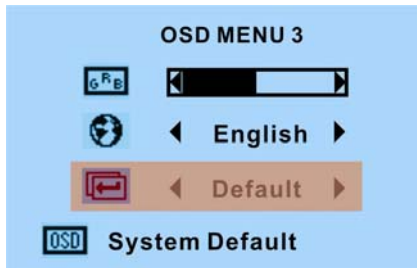

System Default

1. Picture menus

Some picture adjustments are available only when certain input sources are in use.

FUNCTION

(default setting / value)

DESCRIPTION

Source Input

1. Video Input: RCA composite video
2. S-Video Input: Mini DIN5 S-Video
3. YCbCr/YPbPr Input: 3 RCA component video
4. PC Input: VGA/SVGA Computer video
5. DVD Combo: Built-in DVD Player video

Video Mode

1. Dynamic (Default): Is suitable for enjoying colorful movies and TV in a home blackened (little light) lounge room lighting level environment.
2. Static Mode: Is suitable for enjoying DVD movies and TV best viewed in a darkened (not bright) lounge room environment.
3. Theater Mode: Is suitable for playing cinema movies in a totally darkened living room lighting level environment.
4. Gaming Mode: Is suitable for playing gamebox-based video games in a normal living room lighting level environment.

Flip/Mirror

1. Front/Down: Front projection on floor
2. Front/Up: Front projection on ceiling
3. Rear/Up: Rear projection on ceiling
4. Rear/Down: Rear projection on floor

Brightness

Adjusts the brightness of the image. The higher the value, the brighter the image. And lower the setting, darker the image. Adjust this control so the black areas of the image appear just as black and that detail in the dark areas is visible.



Contrast

Adjusts the degree of difference between dark and light in the image. The higher the value, the greater the contrast. Use this to set the peak white level after you have previously adjusted the Brightness setting to suit your selected input and viewing environment.



Color

Increases or decreases the color intensity of the image.

Hue

Adjusts the color tones of the image. The higher the value, the more greenish the image becomes. The lower the value, the more reddish the image becomes.

Language

Language sets the language for the OSD control menus.

Use Left ◀ / Right ▶ on the projector or Left ◀ / Right ▶ on the remote control to select your desired language.

Default

Returns all settings to the factory preset values.

The following settings will still remain: Source, Video Mode, Mirror, Language

Safety instructions for ceiling mounting of your DVD Combo Projector

We want you to have a pleasant experience using your DVD Combo projector, so we need to bring this safety matter to your attention to prevent damage to person and property. If you intend to mount your projector on the ceiling, we strongly recommend that you use a proper fitting DVD Combo projector ceiling mount kit and that you ensure it is securely and safely installed.

If you use a non-DVD Combo brand projector ceiling mount kit, there is a safety risk that the projector may fall from the ceiling due to an improper attachment through the use of the wrong gauge or length screws.

You can purchase a DVD Combo projector ceiling mount kit from the place you purchased your DVD Combo projector. DVD Combo recommends that you also purchase a separate Kensington lock compatible security cable and attach it securely to both the Kensington lock slot on the projector and the base of the ceiling mount bracket. This will perform the secondary role of restraining the projector should its attachment to the mounting bracket become loose.

Troubleshooting

THE PROJECTOR DOES NOT TURN ON.

Cause	Remedy
There is no power from the power cable.	Plug the power cord into the AC inlet on the projector, and plug the power cord into the power outlet. If the power outlet has a switch, make sure that it is switched on.
Attempting to turn the projector on again during the cooling process.	Wait until the cooling down process has completed.

NO PICTURE

Cause	Remedy
The video source is not turned on or connected correctly.	Turn the video source on and check that the signal cable is connected correctly.
The projector is not correctly connected to the input source device.	Check the connection.
The input signal has not been correctly selected.	Select the correct input signal with the Source key on the projector or remote control.
The lens cap is still attached to the lens.	Remove the lens cap.

BLURRED IMAGE

Cause	Remedy
The projection lens is not correctly focused.	Adjust the focus of the lens using the focus adjuster.
The projector and the screen are not aligned properly.	Adjust the projection angle and direction as well as the height of the unit if necessary.
The lens cap is still attached to the lens.	Remove the lens cap.

REMOTE CONTROL DOES NOT WORK

Cause	Remedy
The battery is out of power.	Replace the battery with a new one.
There is an obstacle between the remote control and the projector.	Remove the obstacle.
You are too far away from the projector.	Stand within 6 meters (19.5 feet) of the projector.

Maintenance

Care of the projector

Your projector needs little maintenance. The only thing you need to do on a regular basis is to keep the lens clean.

Never remove any parts of the projector except the lamp. Contact your dealer if other parts need replacing.

Cleaning the lens

Clean the lens whenever you notice dirt or dust on the surface.

- Use a canister of compressed air to remove dust.
- If there is dirt or smears, use lens-cleaning paper or moisten a soft cloth with lens cleaner and gently wipe the lens surface.

Never rub the lens with abrasive materials.

Cleaning the projector case

Before you clean the case, turn the projector off using the proper shutdown procedure as described in "[Shutdown](#)" on [page 30](#) and unplug the power cord.

- To remove dirt or dust, wipe the case with the supplied cleaning cloth.
- To remove stubborn dirt or stains, moisten a soft cloth with water and a neutral pH detergent. Then wipe the case.

Never use wax, alcohol, benzene, thinner or other chemical detergents. These can damage the case.

Storing the projector

If you need to store the projector for an extended time, please follow the instructions below:

- Make sure the temperature and humidity of the storage area are within the recommended range for the projector. Please refer to "[Specifications](#)" on [page 51](#) or consult your dealer about the range.
- Retract the adjuster feet.
- Remove the batteries from the remote control.
- Pack the projector in its original packing or equivalent.

Transporting the projector

It is recommended that you ship the projector with its original packing or equivalent. When you carry the projector yourself, please use the original box or provided soft carry case.

Specifications

Projector specifications

All specifications are subject to change without notice.

Display Technology	Single 0.62-inch Liquid Crystal on Silicon (LCoS) Display
Resolution	800 x 600 x RGB
Contrast Ratio	600:1 (Full On/Full Off)
Lamp Type and Life	50W HID, 3000 hours STD
Maximum Resolution	Video: 1080p (1920 x 1080) PC: SVGA (800 x 600)
Dimensions (WxHxD)	9.5 x 3.5 x 7.9 inches 240mm x 90mm x 200mm
Aspect Ratio	4:3 Standard
Noise Level	<32dB
Projection Lens	f=24.0 – 30.1 mm, F/2.4-2.50
Image Size	30 to 90 inch (1.5 to 3 meters)
Computer Compatibility	SVGA, VGA Compression, VESA standard, PC & Macintosh Compatible
Video Compatibility	NTSC, PAL, SECAM 480i, 480p, 576i, 576p, 720p
Displayable Colors	8-bit per channel color processing
Projection Method	Front/rear/ceiling mount/table top
Power Supply	AC/DC Adapter, 110~240VAC, 50-60Hz, 15VDC 7A
Power Consumption	100 watts, <5 watts in standby mode
Operating Temperature	23 to 102 F (-5 to 42C), 80% Maximum humidity
I/O Connectors	component video, composite video (RCA), S-Video, RGB, Triple IR receivers
OSD Language	Traditional Chinese, Simplified Chinese, English, French, German, Spanish, Italian, Dutch

Warranty

Limited Warranty

DVD Combo warrants this product against any defects in material and workmanship, under normal usage and storage.

Proof of purchase date will be required with any warranty claim. In the event this product is found to be defective within the warranty period, DVD Combo's only obligation and your exclusive remedy shall be replacement of any defective parts (labor included). To obtain warranty service, immediately notify the dealer from which you purchased the product of any defects.

Important: The above warranty shall be void if the customer fails to operate the product in accordance with DVD Combo's written instructions, especially the ambient humidity must be in-between 10% and 90%, temperature in-between 0°C and 40°C, altitude lower than 10000 feet, and avoiding to operate the projector in a dusty environment. This warranty gives you specific legal rights, and you may have other rights, which vary from country to country.

Please refer to the warranty card and limited warranty is subject to change without notice.

For other information, please visit www.chinaprojectors.com.